

for fresher air

Heat Recovery



*ventilation
systems*

Uniclass L7535

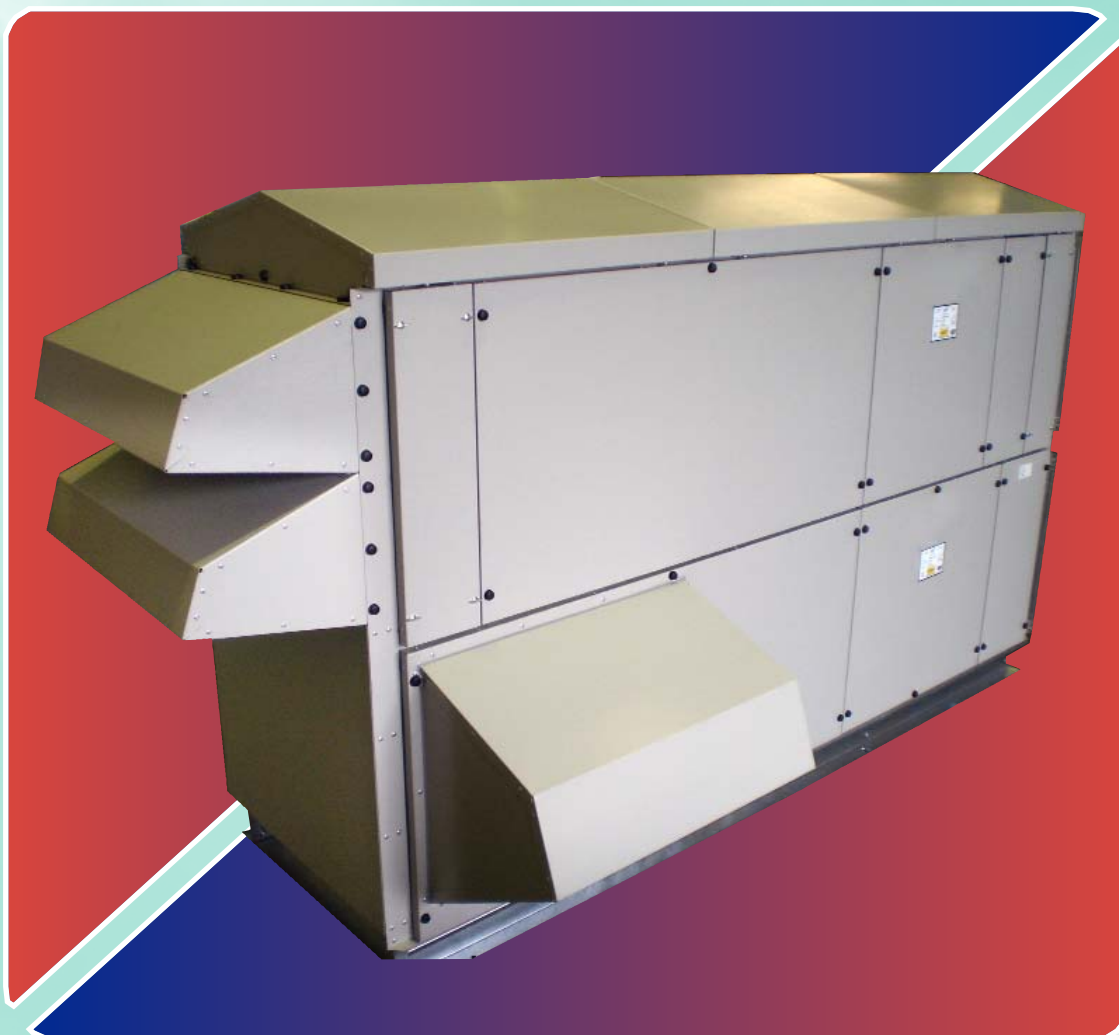

**DIRECT DRIVE - BELT DRIVE - CUSTOM BUILT
EC/DC MOTORS**



Certificate No: GB9455

direct drive - belt drive - custom built *Heat Recovery Units*



Introduction

Vectaire's comprehensive and extensive range of Heat Recovery Units direct drive and belt driven models for plant-room and roof installation are able to deliver up to 2.0 m³/sec ensuring that any installation requirement can be met. Additionally, Vectaire can custom build units with a capacity of up to 12.0 m³/sec.

Design brief

These units are specifically designed to help alleviate the problems of high energy consumption typically occurring when large buildings needing to provide proper ventilation have to draw in air from outside. Heat Recovery Units enable the recovery of at least 50% of the energy which would otherwise be lost with the extraction of contaminated air.

What product to choose?

Stricter rules governing air tightness of buildings means more emphasis on controlled fresh air supply. Heat Recovery Units, which are easy to install and which have a wide variety of options, will effectively ventilate the required area whilst at the same time ensuring the maximum energy efficiency by exchanging the heat on outgoing, contaminated air and warming the cooler incoming fresh air to provide an economical, comfortable atmosphere. Vectaire's range of units, together with comprehensive, computerised design facilities, gives the specifier the ability to choose a unit capacity which ensures a proper level of ventilation.

Flexibility

Vectaire's range of Heat Recovery Units are available in an extensive range with a variety of options which contribute to their versatility of use and ensure that exactly the correct unit can be specified. There are direct drive small plant versions, together with larger models either electrically or hot water heated together with belt driven units for bigger airflow requirements. Combine this with the facility for custom built systems, and the flexibility of design and use is infinite.

Technical Support

With its firm commitment to quality and customer care, Vectaire's technical support staff can help with your requirements.



direct drive - belt drive - custom built *Heat Recovery Units*



Quality Control

Vectaire Heat Recovery Units are manufactured to the highest quality and inspected at every stage of the manufacturing process. All products are built to BS EN ISO 9001. We operate a continuous evaluation of products and services to ensure customer requirements are met in full.



Materials

Vectaire air handling units are generally finished in galvanised, double skinned steel with 25mm thick mineral wool slab insulation. External models have a plastic coated exterior, a pitched weatherproof lid and birdmesh fitted to the intake and discharge cowls.

Cross flow plate heat exchangers prevent cross contamination of air streams and are 100% composite construction with a unique XPS extended surface pattern.

All panel filters are manufactured from bonded and coated continuous spun glass fibre filaments with arrestance of 84% to G3 or G4 grade.



Options

A full range of accessories and controls are also available - these include:

- **thermal wheel**
- **run around coils**
- **intake damper/mixing box and bypass dampers**
- **electric or hot water frost heaters**
- **bag filters**
- **control panels**
- **custom built units up to 12.0 m³/sec**
- **casings**
 - high density mineral wool and barrier matt or plasterboard.
- **additionally**
 - can be constructed in a side by side or stacked layout
 - can be supplied as "flatpack" for on site assembly by Vectaire engineers.



EC motors available

Manufactured in UK to ISO 9001



Heat Recovery Efficiency - direct drive

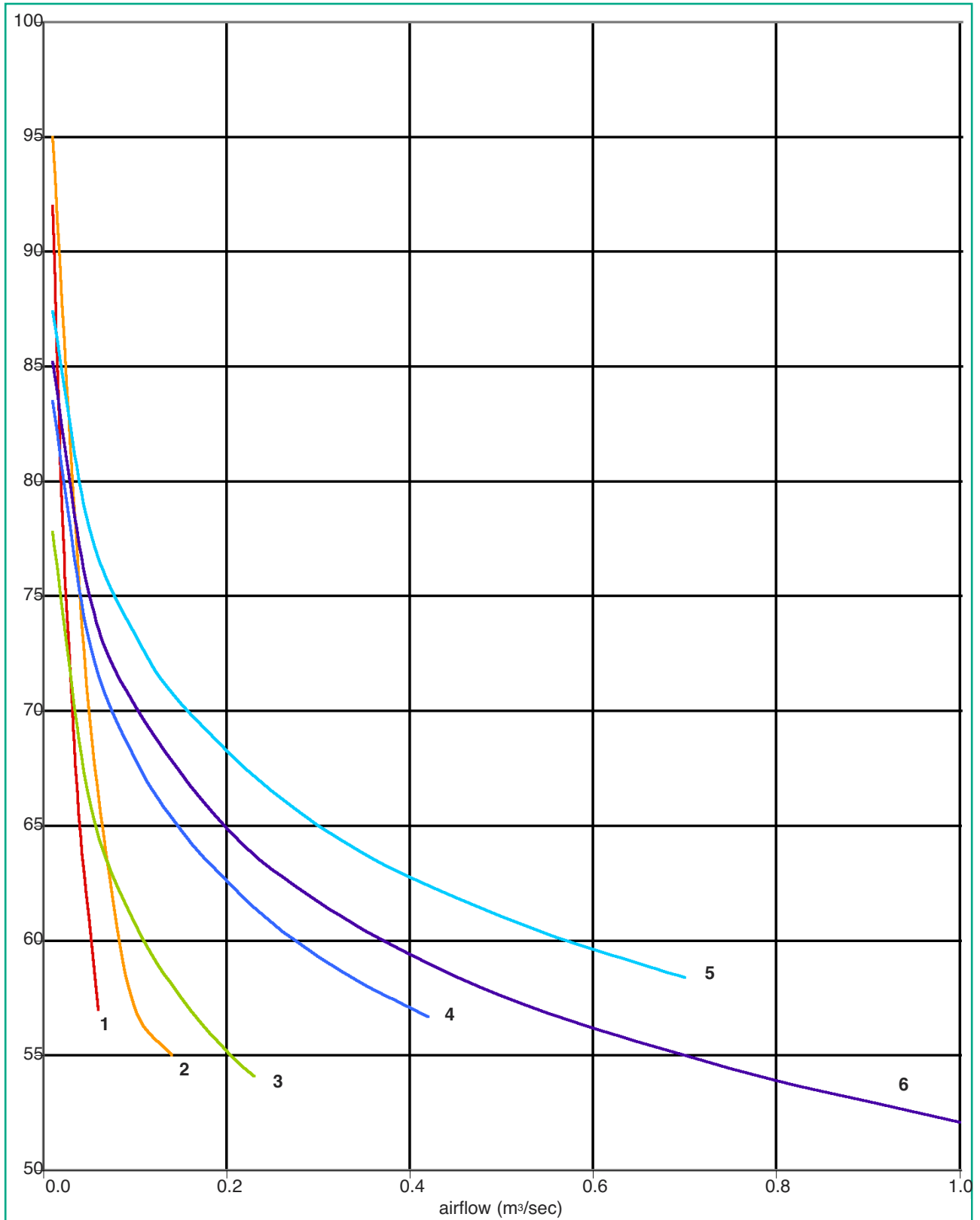

Direct Drive - Heat Recovery Units

HRP1 & HRP2 - *Plant Models*

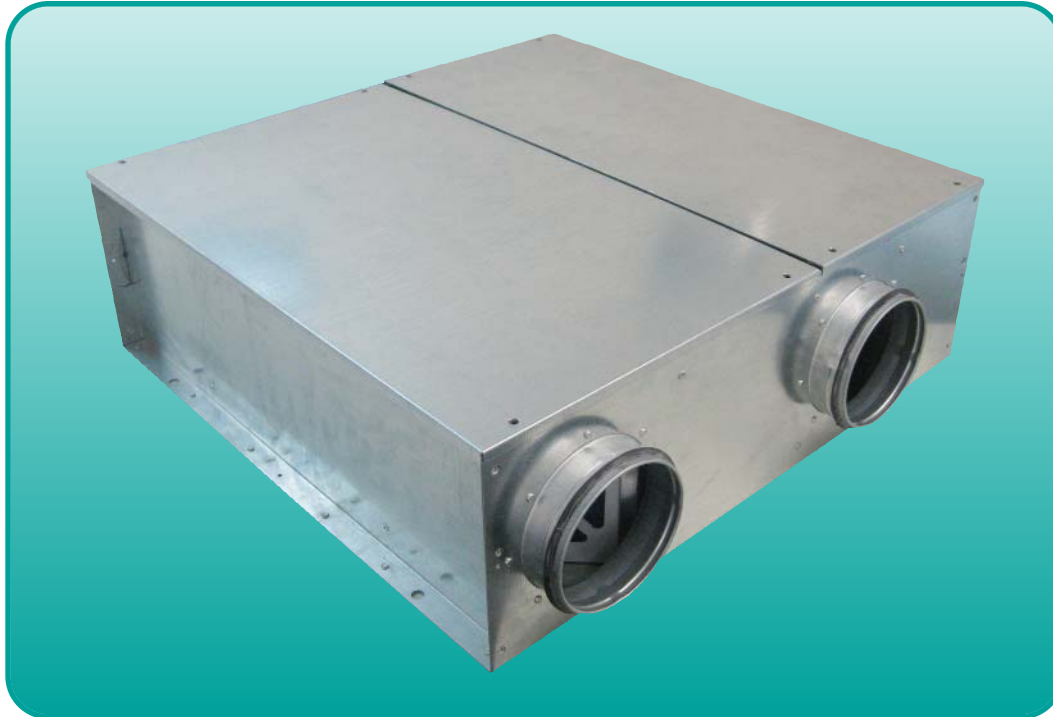

Features

- 2 models
- airflow to .106 m³/sec
- pressure to 320 Pa
- speed controllable
- latent heat exchange with complete separation of supply and extract air flows - no cross contamination
- inlets and outlets are circular spigot type
- panel filters fit into slide-in channels
- rigid casing construction. Integral mounting points are fitted at the bottom of the units to allow either floor or ceiling mounting

Specification

- units are finished in galvanised sheet steel
- single skinned construction with inner acoustic barrier lining
- fans are direct drive, single width, single inlet backward curved centrifugal type
- cross flow plate heat exchangers are of metal construction with efficiencies from 55%
- maximum air temperature 50°C
- panel filters manufactured from bonded and coated spun glass fibre to G3 grade, fitted as standard in easily removable housings. Higher degree of filtration can be provided on request
- **manufactured in UK to ISO 9001**
- **EC Motors available**

Performance & Sound - Fan & Filter

Model	m ³ /sec at Pa										Fan				Speed Controller
	50	75	100	125	150	175	200	225	250	300	Supply	PowerW	FLC A	SC A	
HRP1	0.045	0.040	0.031	0.022	0.017	-	-	-	-	-	230v1ph	23	0.11	0.20	VC1AM
SFP	1.10	1.20	1.52	2.09	2.64	-	-	-	-	-					
HRP2	0.094	0.088	0.081	0.074	0.066	0.058	0.049	0.039	0.029	0.008	230v1ph	58	0.26	0.51	VC1AM
SFP	1.3	1.39	1.50	1.64	1.82	2.05	2.40	2.95	3.87	13.15					

Speed Controller for single fan operation. Consult Sales Office for dual fan operation.

Model	Sound Pressure Level dBA at 3m	Sound Power Levels dB						
		Mid Octave Bands (Hz)						
		125	250	500	1000	2000	4000	8000
HRP1	35	68	71	60	51	50	47	43
HRP2	43	80	76	65	60	60	63	60



Performance Curves

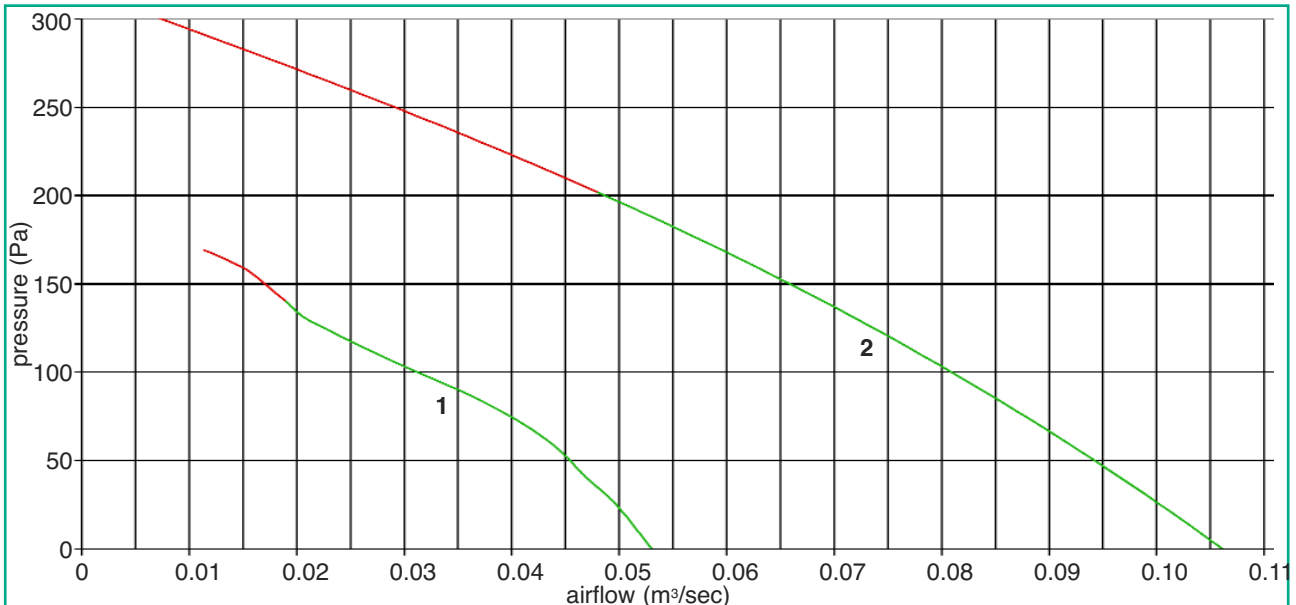

1. **Green** part of curve shows where unit meets L2a Building Regulations Requirements of specific fan power less than 2.5w/l/sec for the entire unit - **red** part of curve shows valid unit selections if the specific fan power limitation does not need to be satisfied.
2. Performance based on filters with a pressure drop 20% above clean

Dimensions

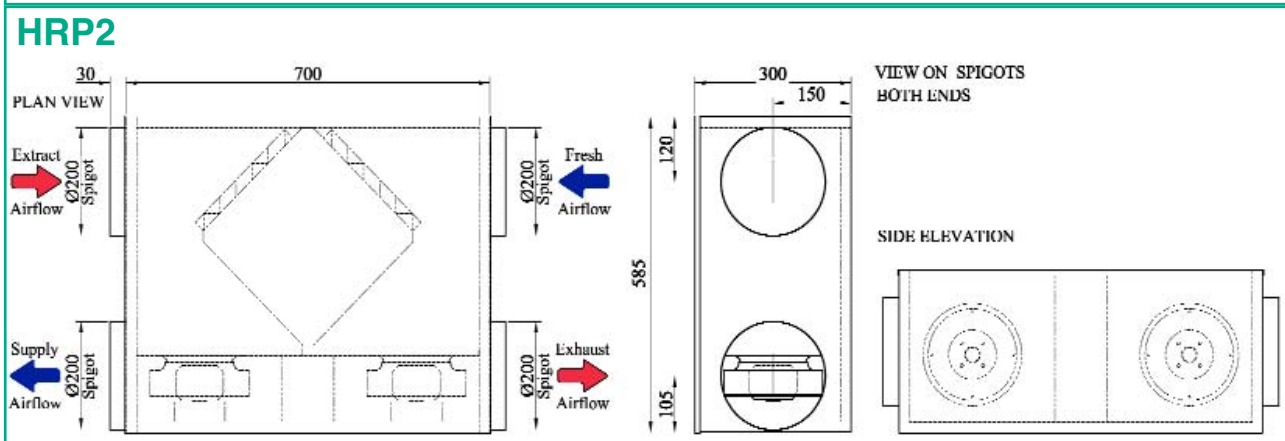
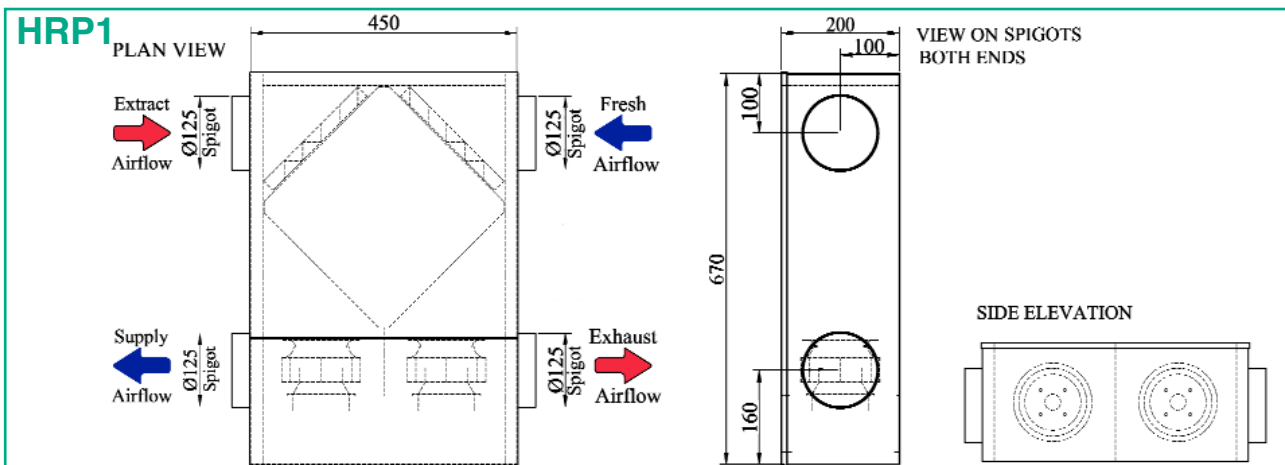

"HRPE/HRRE" - electric heater



Features - PLANT Models

- 8 models
- airflow to .91 m³/sec
- pressure to 500 Pa
- speed controllable
- latent heat exchange with complete separation of supply and exhaust air flows - no cross contamination
- inlets and outlets fitted with "Mez" type duct connecting flanges
- rigid casing construction
- casing can be powder coated to any BS or RAL colour
- panel filters fit into slide-in channels
- filter access doors are fitted with quarter turn fasteners - all other removable panels are retained via set screws fitted with weather caps

Additional Features - WEATHERPROOF Models

- air inlets on external units protected by weather proof cowl and bird guard
- roof mounted units with plastisol exterior in light grey to BS10A05

Specification

- units are finished in galvanised, double skinned steel with 25mm thick mineral wool slab insulation of 45 kg/m³ density (providing high degree of acoustic insulation) (high density mineral wool and barrier matt or plaster board also available for reduced noise breakout)
- fans are direct drive single inlet, single width, back

ward curved centrifugal type

- cross flow plate heat exchangers are 100% composite construction with efficiencies from 55%. Profiled aerofoil inlets and exits ensure minimum pressure drop and even air distribution. Up to 95% recycled material used in construction - they are 100% recyclable.
- electric heater batteries for 1ph and 3ph operation are manufactured from sheathed rod elements with an integral, manual reset thermal cut-out for wiring into control unit
- maximum air temperature 50°C
- panel filters manufactured from bonded and coated spun glass fibre to G3 grade, fitted as standard in easily removable housings. Higher degree of filtration can be provided on request
- **manufactured in UK to ISO 9001**
- **EC Motors available**



COIL



Fan, Filter and Electric Heater Battery

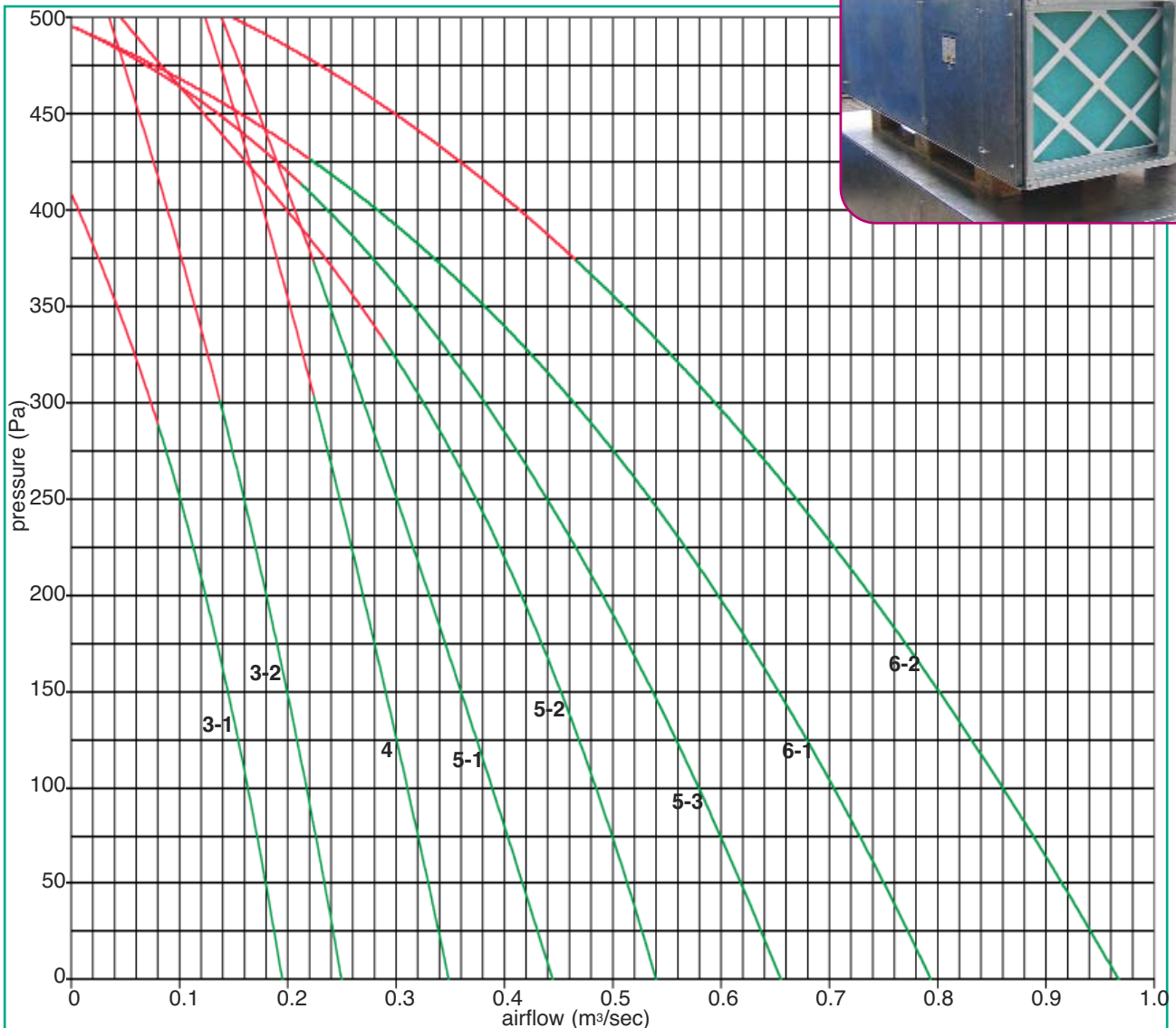

1. **Green** part of curve shows where unit meets L2a Building Regulations Requirements of specific fan power less than 2.5w/l/sec for the entire unit - **red** part of curve shows valid unit selections if the specific fan power limitation does not need to be satisfied.
2. Performance based on filters with a pressure drop 20% above clean

Range		
	Model No	Fan Size
3-1	HRPE/HRRE 3-1	220mm
3-2	HRPE/HRRE 3-2	250mm
4	HRPE/HRRE 4	280mm
5-1	HRPE/HRRE 5-1	280mm
5-2	HRPE/HRRE 5-2	270mm
5-3	HRPE/HRRE 5-3	400mm
6-1	HRPE/HRRE 6-1	400mm
6-2	HRPE/HRRE 6-2	450mm



Fan, Filter and Electric Heater Battery

Model	m³/sec at Pa										Fan				Speed Controller
	50	100	150	200	250	300	350	400	450	500	Supply	PowerW	FLC A	SC A	
HR E 3-1	0.180	0.163	0.144	0.123	0.101	0.074	0.043	0.007	-	-	230v1ph	85	0.38	0.89	VC1AM
SFP	1.14	1.29	1.48	1.72	2.06	2.64	4.07	19.84	-	-					
HR E 3-2	0.230	0.210	0.200	0.179	0.160	0.137	0.115	0.089	0.063	0.035	230v1ph	155	0.70	1.70	VC1AM
SFP	1.26	1.42	1.62	1.85	2.13	2.48	2.93	3.61	4.79	7.76					
HR E 4	0.33	0.31	0.29	0.27	0.25	0.22	0.20	0.18	0.15	0.12	230v1ph	225	1.00	2.40	VC1AM
SFP	1.26	1.46	1.67	1.89	2.17	2.46	2.80	3.20	3.75	4.47					
HR E 5-1	0.41	0.39	0.36	0.33	0.30	0.27	0.24	0.21	0.17	0.14	230v1ph	225	1.00	2.40	VC1AM
SFP	0.44	0.70	0.97	1.24	1.59	1.89	2.30	2.75	3.30	4.08					
HR E 5-2	0.51	0.48	0.45	0.41	0.37	0.32	0.26	0.19	0.12	0.05	230v1ph	280	1.23	3.60	VC1AM
SFP	1.89	1.94	1.99	2.07	2.17	2.33	2.61	3.15	4.46	10.13					
HR E 5-3	0.62	0.58	0.54	0.49	0.44	0.38	0.31	0.24	0.14	-	230v1ph	480	2.40	6.30	VC4AM
SFP	0.75	0.85	0.96	1.10	1.26	1.47	1.77	2.27	3.57	-					
HR E 6-1	0.75	0.70	0.65	0.59	0.53	0.46	0.38	0.28	0.15	-	230v1ph	480	2.40	6.30	VC4AM
SFP	0.50	0.60	0.72	0.86	1.02	1.23	1.53	2.02	3.27	-					
HR E 6-2	0.91	0.86	0.80	0.74	0.67	0.59	0.51	0.41	0.30	0.15	230v ph	680	3.00	5.40	VC4AM
SFP	1.44	1.53	1.62	1.74	1.88	2.07	2.33	2.73	3.52	6.19					

See page 7 for Heater Battery Details

A 3ph electricity supply is recommend for the heater battery if it is rated over 18kw (regardless of the fact that the fan is single-phase)

SFP = Specific Fan Power

Speed Controller for single fan operation. Consult Sales Office for dual fan operation.

Fan Outlet Sound Levels

Model	Sound Pressure Level dBA at 3m	Sound Power Levels dB						
		Mid Octave Bands (Hz)						
		125	250	500	1000	2000	4000	8000
HR E 3-1	40	68	72	83	73	67	65	77
HR E 3-2	44	78	78	82	73	68	71	79
HR E 4	44	77	75	86	74	73	72	75
HR E 5-1	47	86	77	84	76	72	73	75
HR E 5-2	44	77	75	86	74	73	72	82
HR E 5-3	52	89	86	80	73	65	63	71
HR E 6-1	52	89	86	80	73	65	63	71
HR E 6-2	48	85	82	76	69	61	59	67



Electric Heater Battery

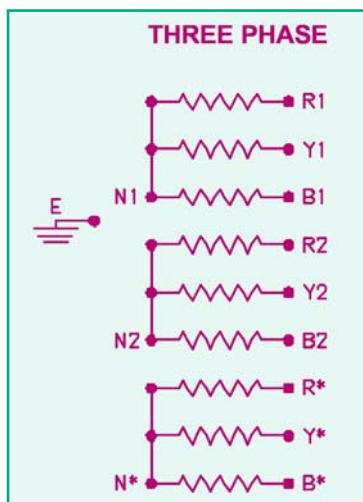
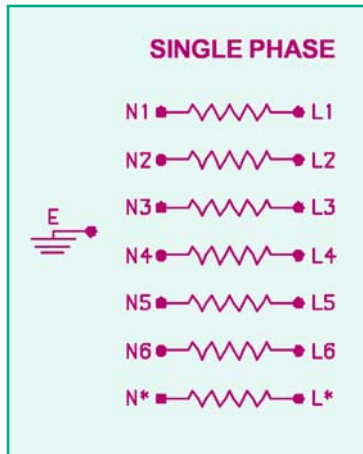

Model	kW Rating	Single Phase Steps					3 Phase Steps			
		1	2	3	4	6	1	2	3	4
HR E 3	3.0	✓	✓							
	4.5	✓		✓						
	6.0	✓	✓	✓			✓			
	7.5	✓		✓			✓			
	9.0	✓	✓	✓			✓	✓		
	12.0		✓	✓	✓	✓	✓	✓		
HR E 4	6.0	✓	✓	✓			✓			
	7.5	✓		✓			✓			
	9.0	✓	✓	✓			✓	✓		
	12.0		✓	✓	✓	✓	✓	✓		
	15.0		✓	✓		✓	✓	✓		
	18.0		✓	✓		✓	✓	✓		
HR E 5	15.0		✓	✓		✓	✓	✓		
	18.0		✓	✓		✓	✓	✓		
	21.0							✓		
	24.0							✓		✓
	27.0							✓	✓	
	30.0							✓		✓
HR E 6	21.0							✓		
	24.0							✓		✓
	27.0							✓	✓	
	30.0							✓		✓
	36.0							✓	✓	✓
	45.0							✓	✓	



Heater ratings can be calculated using the following formula: $kW = m^3/sec \times 1.21 \times \text{Temp rise } ^\circ C$
 Dependent on external system resistance and airflow achieved, the temperature rise should not exceed 35°C

"HRPW/HRRW" - LPHW heater



Features - PLANT Models

- 8 models
- airflow to .93 m³/sec
- pressure to 500 Pa
- speed controllable
- latent heat exchange with complete separation of supply and exhaust air flows - no cross contamination
- inlets and outlets fitted with "Mez" type duct connecting flanges
- rigid casing construction
- casing can be powder coated to any BS or RAL colour
- panel filters fit into slide-in channels
- filter access doors are fitted with quarter turn fasteners - all other removable panels are retained via set screws fitted with weather caps

Additional Features - WEATHERPROOF Models

- air inlets on external units protected by weather proof cowl and bird guard
- externally mounted units constructed in galvanised steel with plastisol exterior in light grey to BS10A05

Specification

- units are finished in galvanised, double skinned steel with 25mm thick mineral wool slab insulation of 45 kg/m³ density (providing high degree of acoustic insulation) (high density mineral wool and

barrier matt or plaster board also available for reduced noise breakout)

- fans are direct drive single inlet, single width, backward curved centrifugal type
- LPHW batteries are constructed from copper tubes mechanically bonded onto aluminium fins supplied with standard BSP male connections
- maximum air temperature 50°C
- panel filters manufactured from bonded and coated spun glass fibre to G3 grade, fitted as standard in easily removable housings. Higher degree of filtration can be provided on request
- **manufactured in UK to ISO 9001**
- **EC Motors available**



LPHW COIL



Fan, Filter and LPHW Heater Battery

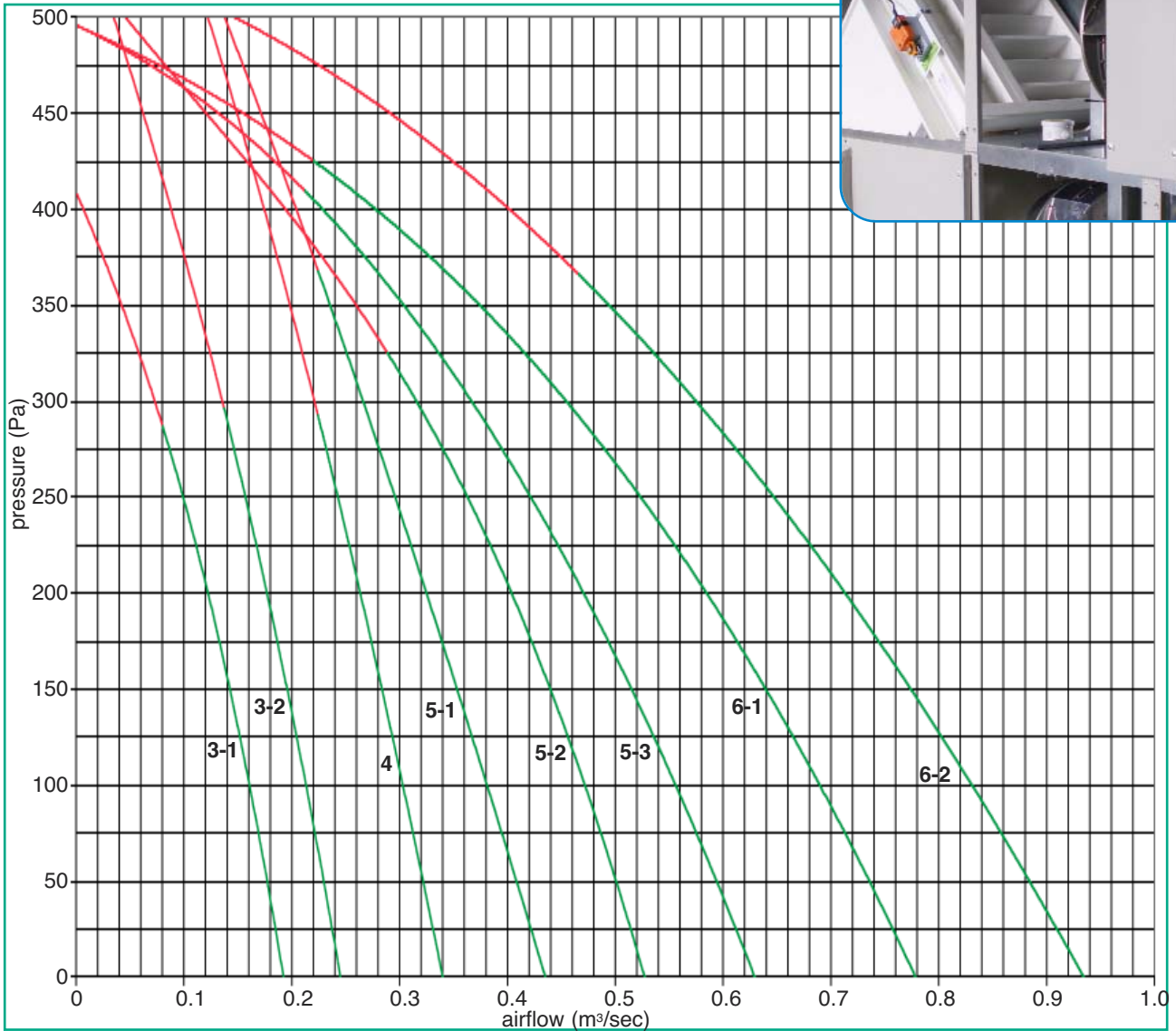

1. **Green** part of curve shows where unit meets L2a Building Regulations Requirements of specific fan power less than 2.5w/l/sec for the entire unit - **red** part of curve shows valid unit selections if the specific fan power limitation does not need to be satisfied.
2. Performance based on filters with a pressure drop 20% above clean

Range		
	Model No	Fan Size
3-1	HRPW/HRRW 3-1	220mm
3-2	HRPW/HRRW 3-2	250mm
4	HRPW/HRRW 4	280mm
5-1	HRPW/HRRW 5-1	280mm
5-2	HRPW/HRRW 5-2	270mm
5-3	HRPW/HRRW 5-3	400mm
6-1	HRPW/HRRW 6-1	400mm
6-2	HRPW/HRRW 6-2	450mm



Fan, Filter and LPHW Heater Battery

Model	m³/sec at Pa										Fan				Speed Controller
	50	100	150	200	250	300	350	400	450	500	Supply	PowerW	FLC A	SC A	
HR W 3-1	0.177	0.161	0.143	0.122	0.099	0.073	0.043	0.007	-	-	230v 1ph	85	0.38	0.89	VC1AM
SFP	1.16	1.30	1.49	1.74	2.09	2.66	4.07	19.83	-	-					
HR W 3-2	0.230	0.213	0.195	0.177	0.156	0.136	0.112	0.087	0.062	0.035	230v 1ph	155	0.70	1.70	VC1AM
SFP	1.30	1.47	1.67	1.89	2.17	2.50	2.97	3.68	4.85	7.76					
HR W 4	0.322	0.304	0.283	0.255	0.242	0.222	0.198	0.173	0.150	0.123	230v 1ph	225	1.00	2.40	VC1AM
SFP	1.38	1.52	1.76	2.08	2.25	2.54	2.87	3.31	3.79	4.53					
HR W 5-1	0.408	0.380	0.353	0.326	0.296	0.265	0.236	0.205	0.172	0.138	230v 1ph	225	1.00	2.40	VC1AM
SFP	0.52	0.77	1.03	1.30	1.61	0.96	2.32	2.78	3.35	4.08					
HR W 5-2	0.501	0.472	0.441	0.404	0.363	0.316	0.259	0.195	0.121	0.047	230v 1ph	280	1.23	3.60	VC1AM
SFP	1.91	1.96	2.02	2.10	2.21	2.37	2.66	3.19	4.52	10.13					
HR W 5-3	0.594	0.556	0.515	0.470	0.423	0.367	0.305	0.229	0.133	-	230v 1ph	480	2.40	6.30	VC4AM
SFP	0.81	0.91	1.02	1.16	1.32	1.54	1.83	2.34	3.61	-					
HR W 6-1	0.735	0.688	0.640	0.585	0.523	0.454	0.374	0.279	0.154	-	230v 1ph	480	2.40	6.30	VC4AM
SFP	0.53	0.64	0.75	0.89	1.06	1.27	1.56	2.04	3.31	-					
HR W 6-2	0.884	0.831	0.774	0.714	0.647	0.575	0.495	0.403	0.292	0.149	230v 1ph	680	3.00	5.40	VC4AM
SFP	1.49	1.57	1.67	1.79	1.93	2.12	2.39	2.80	3.59	6.26					

Performance curves are based on "clean filter" conditions. An additional 80Pa should be added to the external pressure of the product for unit selection at "mean dirty" conditions.

SFP = Specific Fan Power

Speed Controller for single fan operation. Consult Sales Office for dual fan operation.

Fan Outlet Sound Levels

Model	Sound Pressure Level dBA at 3m	Sound Power Levels dB						
		Mid Octave Bands (Hz)						
		125	250	500	1000	2000	4000	8000
HR W 3-1	40	68	72	83	73	67	65	77
HR W 3-2	44	78	78	82	73	68	71	79
HR W 4	44	77	75	86	74	73	72	75
HR W 5-1	47	86	77	84	76	72	73	75
HR W 5-2	44	77	75	86	74	73	72	82
HR W 5-3	52	89	86	80	73	65	63	71
HR W 6-1	52	89	86	80	73	65	63	71
HR W 6-2	48	85	82	76	69	61	59	67



Flat Configuration

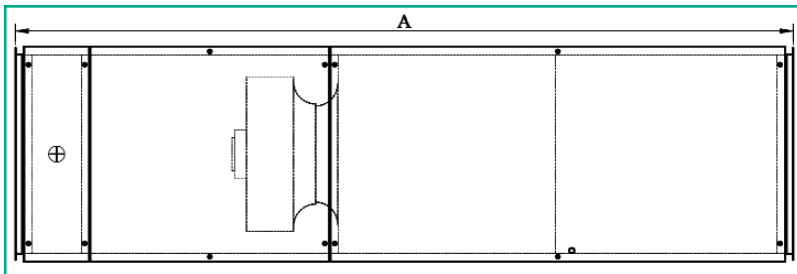
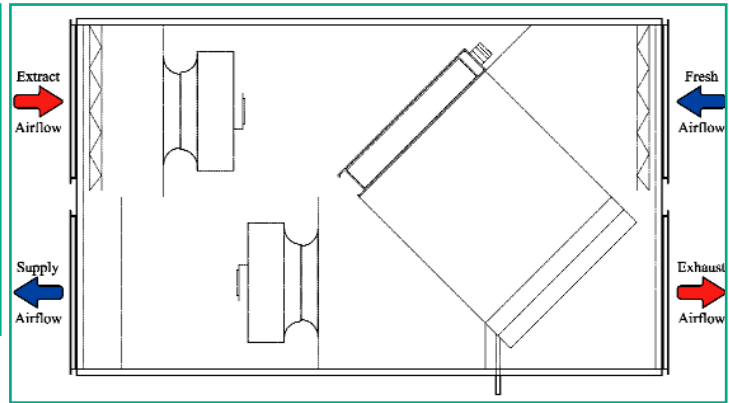
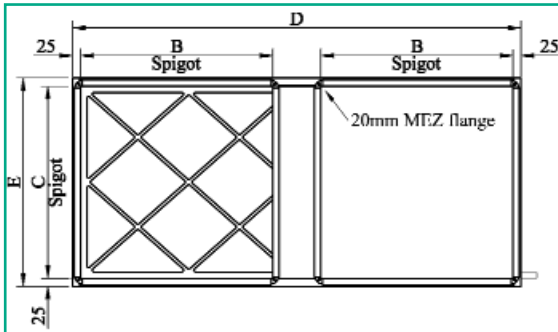

Model Plant	A mm	B mm	C mm	D mm	E mm	kg
HRP3	1450	350	400	850	450	150
HRP4	1650	400	450	1000	500	175
HRP5	2150	500	550	1150	600	275
HRP6	2350	600	600	1400	650	325

Stacked Configuration

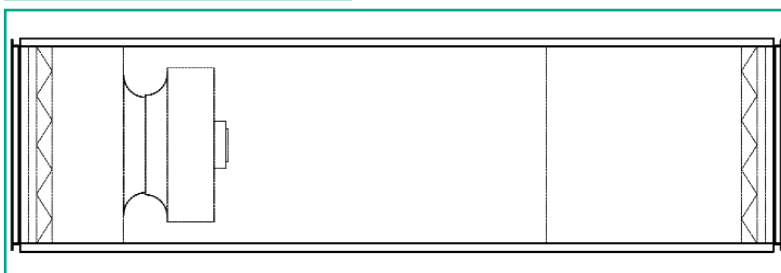
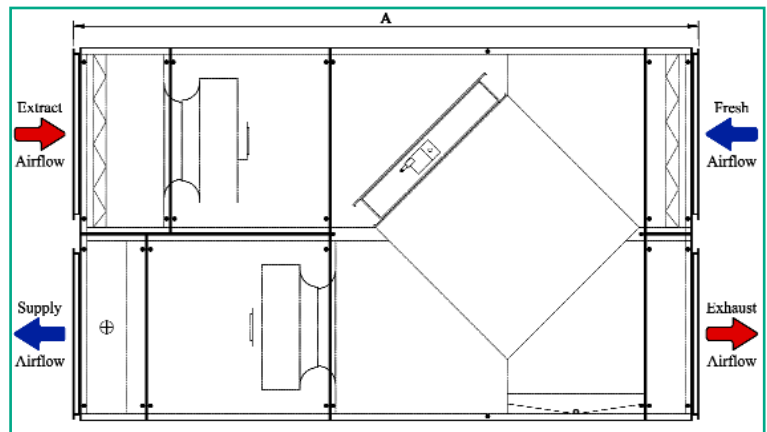
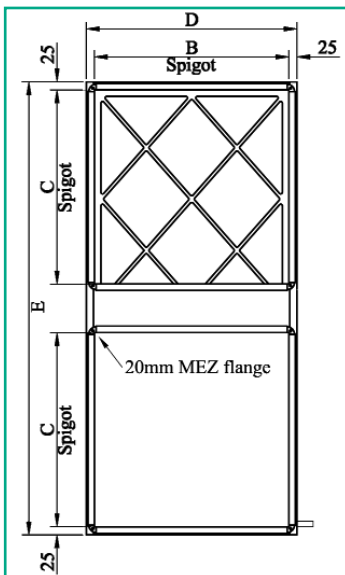

Model Plant	A mm	B mm	C mm	D mm	E mm	kg
HRP3	1550	475	350	525	875	150
HRP4	1700	525	400	575	1000	175
HRP5	2150	625	500	675	1150	275
HRP6	2350	675	600	725	1400	325



Fan, Filter and Heater Battery - Weatherproof Models Flat Configuration

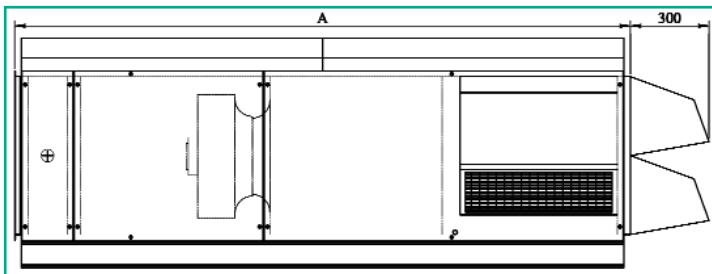
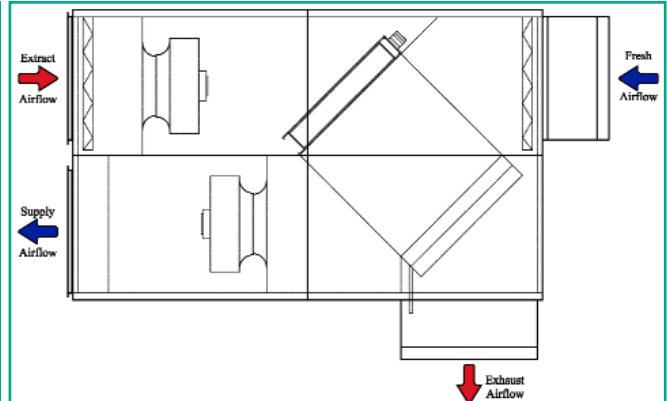
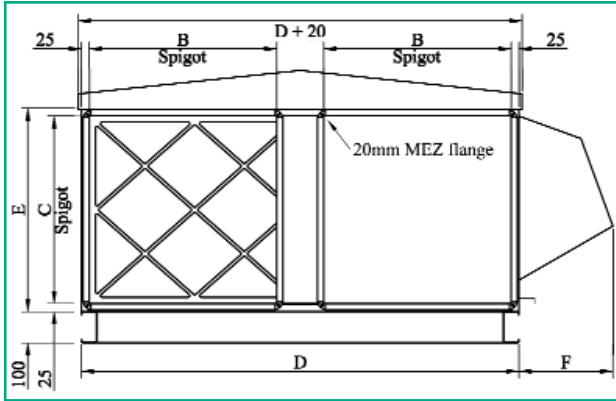

Modl Roof	A mm	B mm	C mm	D mm	E mm	F mm	kg
HRR3	1450	350	400	850	450	300	175
HRR4	1650	400	450	1000	500	300	225
HRR5	2150	500	550	1150	600	350	350
HRR6	2350	600	600	1400	650	350	425

Stacked Configuration

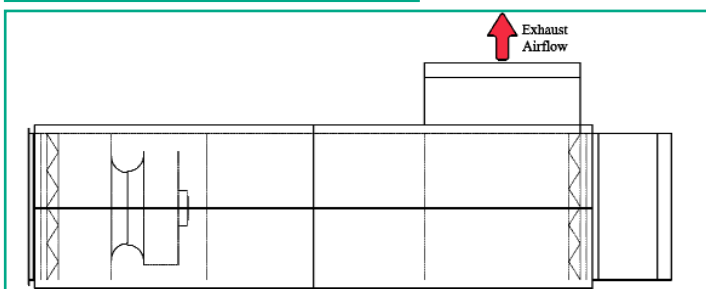
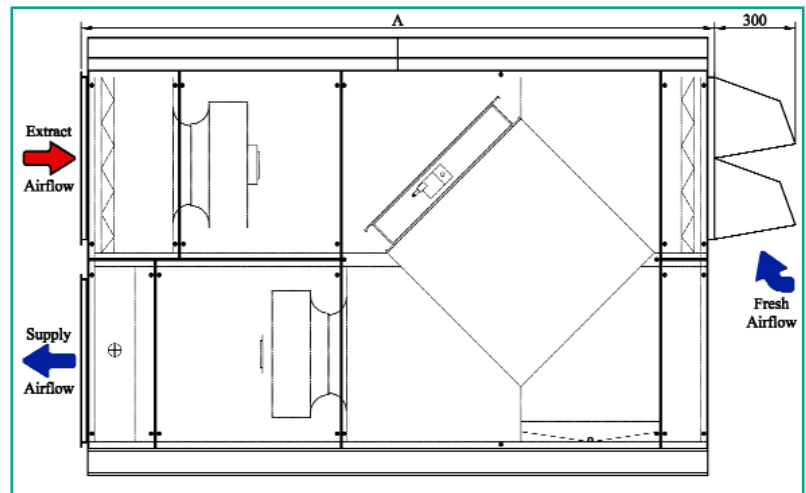
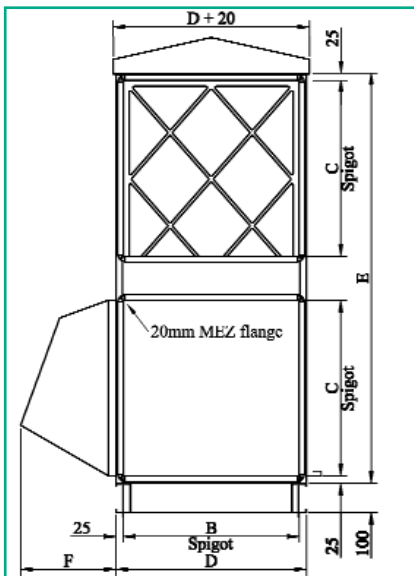

Modl Roof	A mm	B mm	C mm	D mm	E mm	F mm	kg
HRR3	1550	475	350	525	875	300	200
HRR4	1700	525	400	575	1000	300	225
HRR5	2150	625	500	675	1150	350	350
HRR6	2350	675	600	725	1400	350	350

Direct Drive - Heat recovery Units

Silencers



Pressure Drop

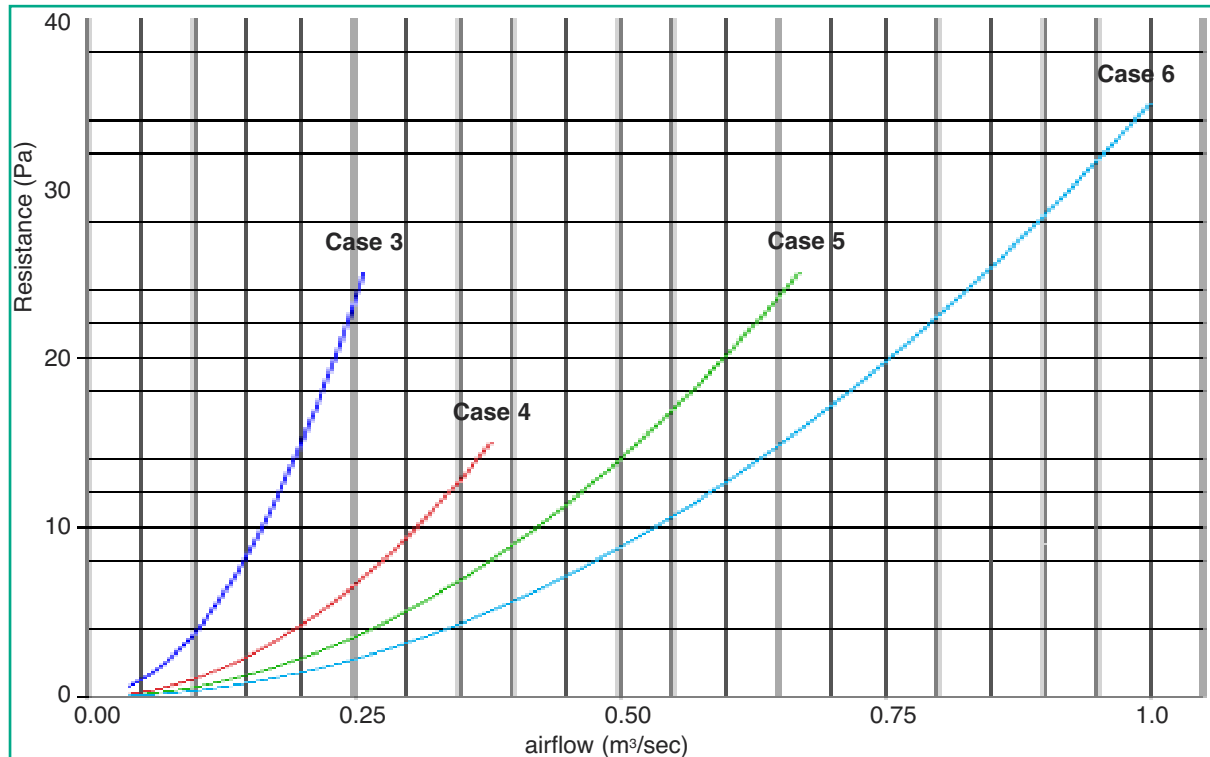

Insertion Loss

Model	Length mm	Attenuation: Insertion loss - dB - mid frequency Hz						
		125	250	500	1000	2000	4000	8000
Case 3	900	11	19	34	45	45	39	28
	1200	14	26	46	55	55	52	38
	1800	20	34	50	55	55	55	45
Case 4	900	9	16	30	39	39	31	26
	1200	12	23	40	51	51	41	29
	1800	17	30	47	55	55	49	36
Case 5	900	9	16	30	39	39	31	26
	1200	12	23	40	51	51	41	29
	1800	17	30	47	55	55	49	36
Case 6	900	9	16	30	39	39	31	26
	1200	12	23	40	51	51	41	29
	1800	17	30	47	55	55	49	36

All silencers are sized to match the connection spigot sizes of the main unit. All silencers have:

- 20mm MEZ flanges
- Glass tissue faced pods
- Galvanised steel casing

Heat Recovery Units *Control Panels*



HRCP (no heating)

Epoxy painted steel enclosure
Door interlock isolator
Individual switches, and run and trip indicators for fan
Panel live indicator
Individual fuses for fan
Mains input: 400V, 50Hz, 3Ph and N;
or 230V, 50Hz, 1Ph
Maximum output: Fans 3A max FLC supply & extract
single phase motors

Electric Heating

HRCP-E-Model 1

Epoxy painted steel enclosure
Door interlock isolator
Individual switches, and run and trip indicators for fan and
heater
Panel live indicator
Individual fuses for fan and heater elements
Mains input: 400v, 50Hz, 3ph and N: or 230v, 50Hz, 1ph
Maximum output: Heater 18kW, single phase
Fans 3A max FLC supply and extract single
phase motors
Maximum number of heater steps: 6
Fan run-on timer: 2 mins approx

HRCP-E-Model 2

Epoxy painted steel enclosure
Door interlock isolator
Individual switches, and run and trip indicators for fan and
heater
Panel live indicator
Individual fuses for fan and heater element
Mains input: 400v, 50Hz, 3ph and N
Maximum output: Heater 45kW, three phase
Fans 3A max FLC supply and extract single
phase motors
Maximum number of heater steps: 3
Fan run-on timer: 2 mins approx

Hot Water Heating

HRCP-W

Epoxy painted steel enclosure
Door interlock isolator
Individual switches, and run and trip indicators for fan and heater
Panel live indicator
Individual fuses for fan and heater element
Mains input: 400v, 50Hz, 3ph and N: or 230V, 50Hz 1ph
Maximum output: Fans 3A max FLC supply and extract single phase
motors
Heater signal: 0-10v modulating

Standard Features and Options

Standard Features

230v face and by-pass damper motor open/close signal
Face and by-pass duct stat
7 day time clock
BMS enable/volt free contact
Frost stat (water heater only)

Standard Options

Weatherproofing
Frost EHB/LPHW coil
Intake and return air shut-off dampers
Dirty filter indicators
Internally mounted speed controllers
Extract run/stand-by auto-changeover for twin fan units
3 phase fan motors



" HRP7-HRP8: HRR7-HRR8



Features - PLANT Models

- 2 models
- airflow to 2.0 m³/sec
- wide selection of control panels available
- EHB or LPHW
- latent heat exchange with complete separation of supply and exhaust air flows - no cross contamination
- inlets and outlets fitted with "Mez" type duct connecting flanges
- rigid casing construction
- casing can be powder coated to any BS or RAL colour
- panel filters fit into slide-in channels
- filter access doors are fitted with quarter turn fasteners - all other removable panels are retained via set screws fitted with weather caps

Additional Features - WEATHERPROOF Models

- 2 models
- air inlets on external units protected by weather proof cowl and bird guard
- roof mounted units with plastisol exterior in light grey to BS10A05

Specification

- units are finished in galvanised, double skinned steel with 25mm thick mineral wool slab insulation of 45 kg/m³ density (providing high degree of acoustic insulation) (high density mineral wool and barrier matt or plaster board also available for reduced noise breakout)
- fans are belt drive double inlet, double width, for ward curved centrifugal type, mounted on integral

- anti-vibration mounts
- motors - with thermal cut-out protection and a transit bolt fitted to avoid damage in transit
- cross flow plate heat exchangers are 100% composite construction with efficiencies from 50%. Profiled aerofoil inlets and exits ensure minimum pressure drop and even air distribution. Up to 95% recycled material used in construction - they are 100% recyclable.
- electric heater batteries for 1ph and 3ph operation are manufactured from sheathed rod elements with an integral, manual reset thermal cut-out for wiring into control unit
- maximum air temperature 50°C
- panel filters manufactured from reinforced non-woven media with metal support grid to G4 grade, fitted as standard in easily removable housings. Higher degree of filtration can be provided on request
- **manufactured in UK to ISO 9001**





Heat Recovery Efficiency

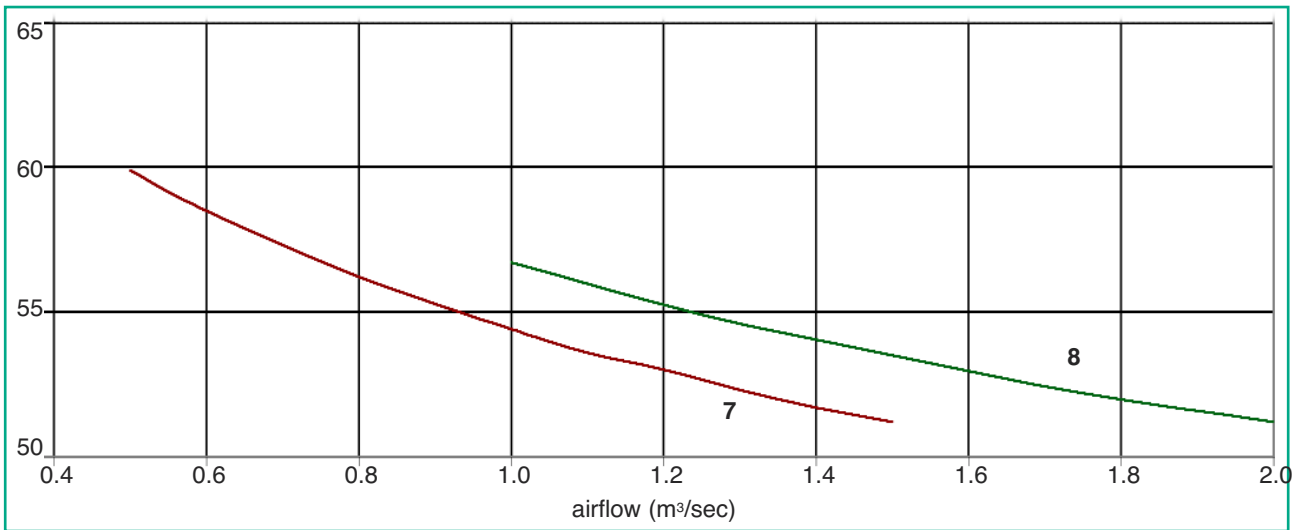

Fan, Filter and Heater Battery

Unit Selection Information

Model	Duty - m³/sec															
	0.5	0.6	0.7	0.8	0.9	1.0	1.1	1.2	1.3	1.4	1.5	1.6	1.7	1.8	1.9	2.0
HRP/R 7	x	x	x	x	x	x	x	x	x	x	x					
HRP/R 8						x	x	x	x	x	x	x	x	x	x	x

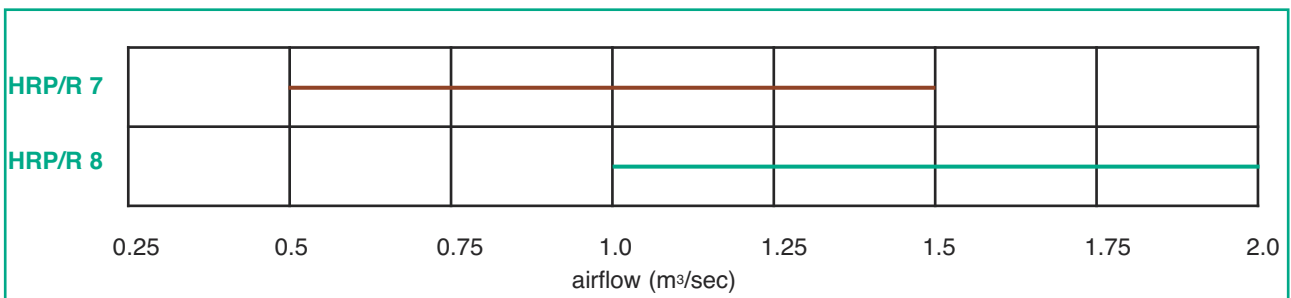

Typical Fan Outlet Sound Levels

Model	Sound Pressure Level dBA at 3m	Sound Power Levels dB							
		Mid Octave Bands (Hz)							
		63	125	250	500	1000	2000	4000	8000
HRP/R 7	39	76	75	72	70	69	67	63	59
HRP/R 8	42	79	78	75	73	72	70	66	62

N.B sound levels based on example, ie
 Size 7 : 1.00 m³/sec @ 250 Pa Ext
 Size 8 : 1.75 m³/sec @ 250 Pa Ext

Belt Driven - Heat Recovery Units *Silencers*



Pressure Drop

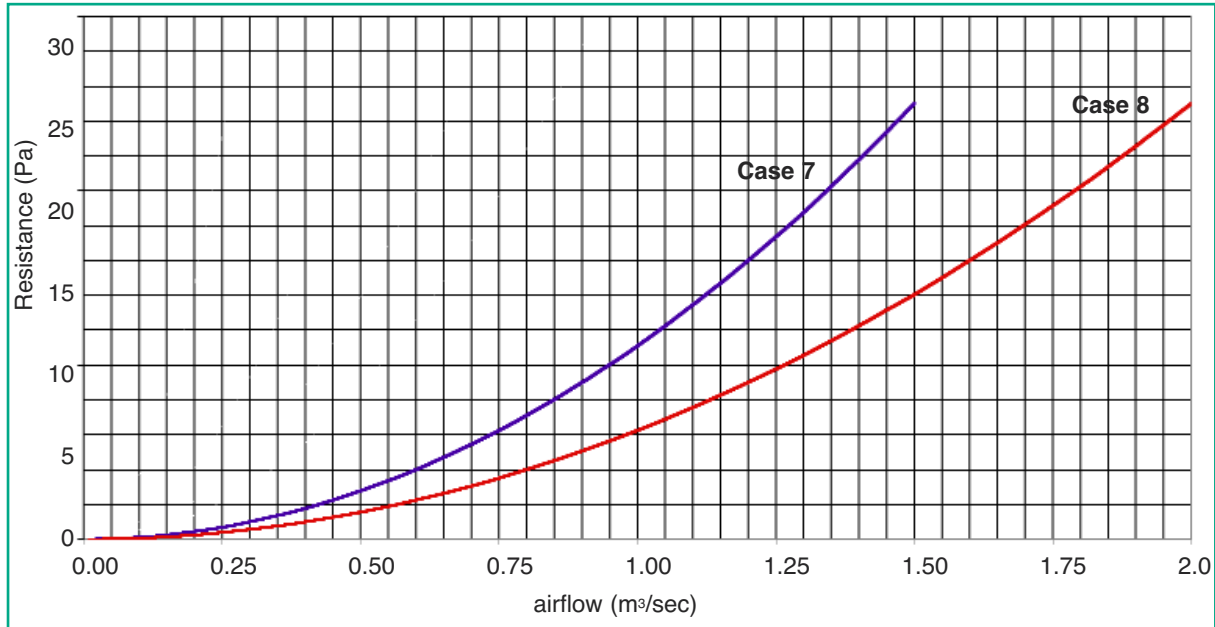

Insertion Loss

Model	Length mm	Attenuation: Insertion loss - dB - mid frequency Hz							
		63	125	250	500	1000	2000	4000	8000
Case 7	900	5	9	16	30	39	39	31	26
	1200	6	12	23	40	51	51	41	29
	1800	9	17	30	47	55	55	49	36
Case 8	900	5	9	16	30	39	39	31	26
	1200	6	12	23	40	51	51	41	29
	1800	9	17	30	47	55	55	49	36

All silencers are sized to match the connection spigot sizes of the main unit. We advise that silencers for use on supply discharge are sized to include a long plenum on the unit side. This 300mm will not increase the attenuation of the silencers.

All silencers have:

- 20mm MEZ flanges
- Glass tissue faced pods
- Galvanised steel casing



Electric Heater Battery

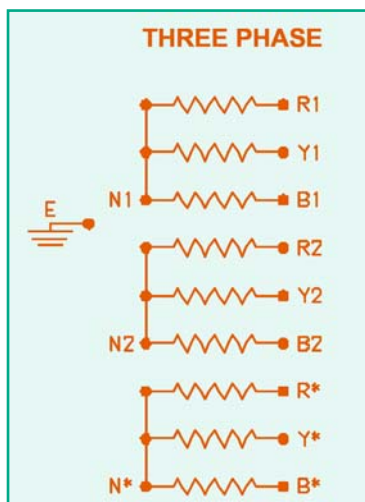
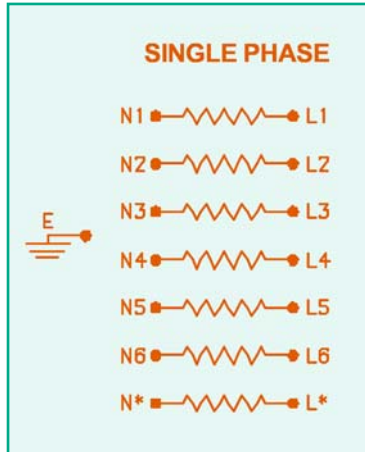

Model	kW Rating	Single Phase Steps					3 Phase Steps			
		1	2	3	4	6	1	2	3	4
HRP/R 7	18.0	✓	✓	✓		✓	✓	✓		
	24.0						✓	✓		✓
	27.0							✓	✓	
	36.0							✓	✓	✓
	45.0							✓	✓	
	54.0							✓	✓	✓
	63.0							✓	✓	
HRP/R 8	27.0						✓	✓	✓	
	36.0							✓	✓	✓
	45.0							✓	✓	
	54.0							✓	✓	✓
	63.0							✓	✓	
	72.0								✓	✓
	81.0							✓	✓	

Heater ratings can be calculated using the following formula: $kW = m^3/sec \times 1.21 \times \text{Temp rise } ^\circ C$
 Dependent on external system resistance and airflow achieved, the temperature rise should not exceed 35°C

HRP - *Dimensions*

Fan, Filter and Heater Battery - Plant Models Flat Configuration

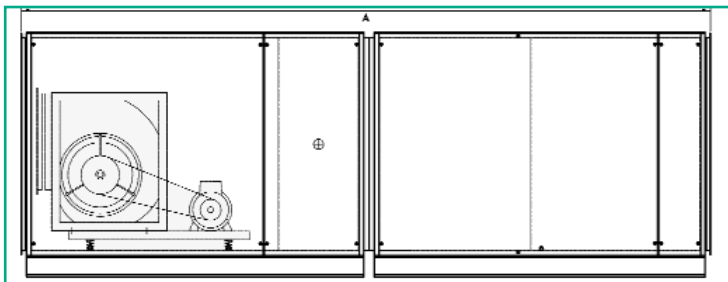
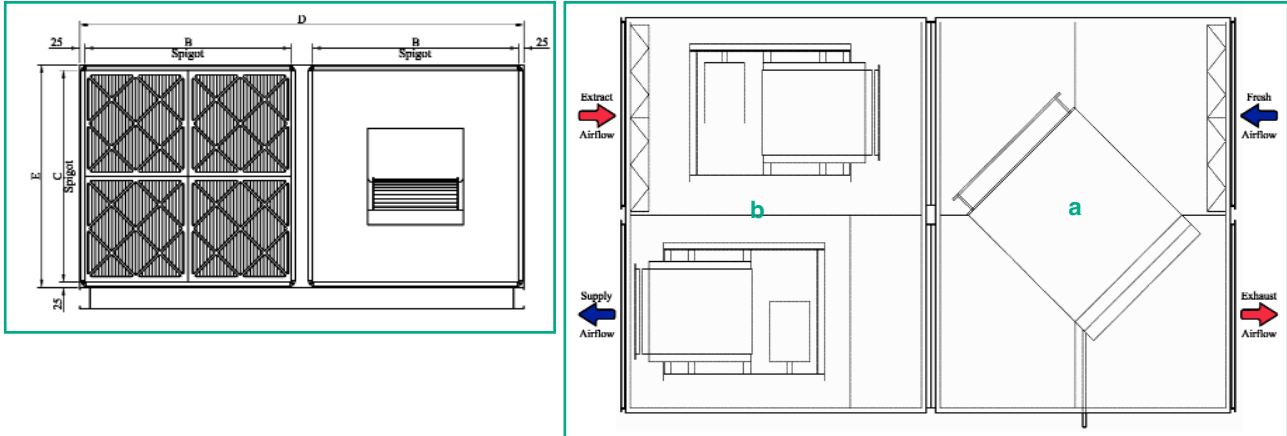

Model Plant	A mm	B mm	C mm	D mm	E mm	kg a	kg b
HRP7	3200	775	800	1700	850	310	450
HRP8	3200	975	1000	2100	1050	430	590

Stacked Configuration

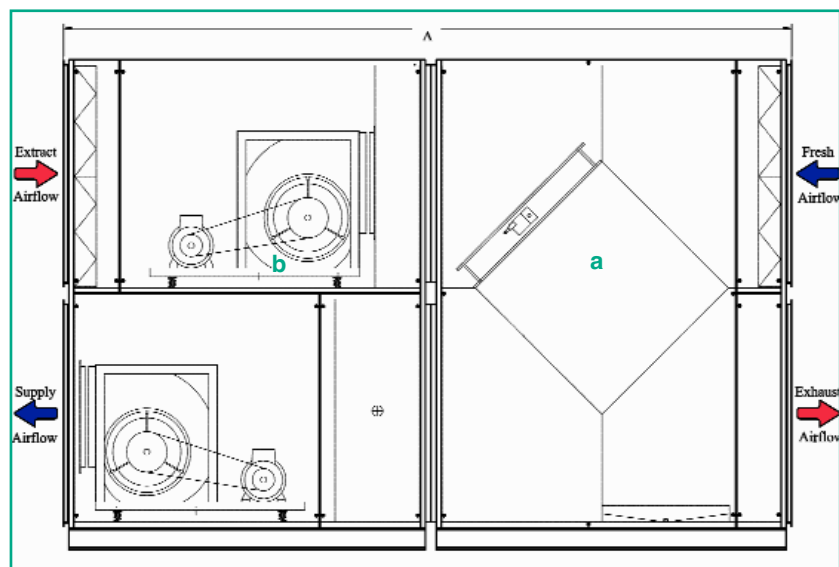
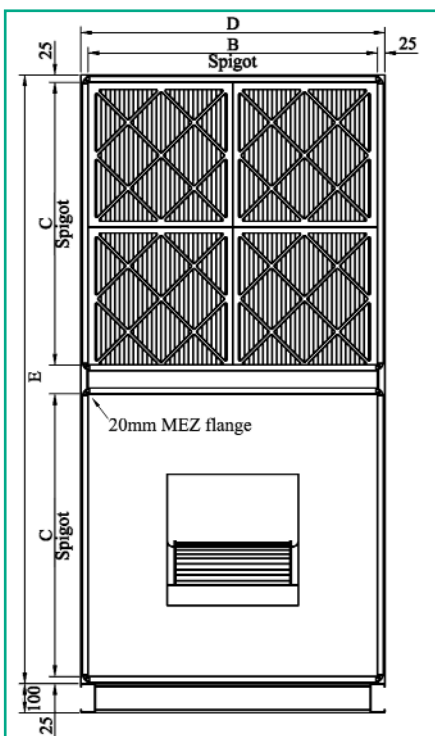

Model Plant	A mm	B mm	C mm	D mm	E mm	kg a	kg b
HRP7	3200	800	775	850	1700	320	460
HRP8	3300	1000	975	1050	2100	390	550

Fan, Filter and Heater Battery - Weatherproof Models Flat Configuration

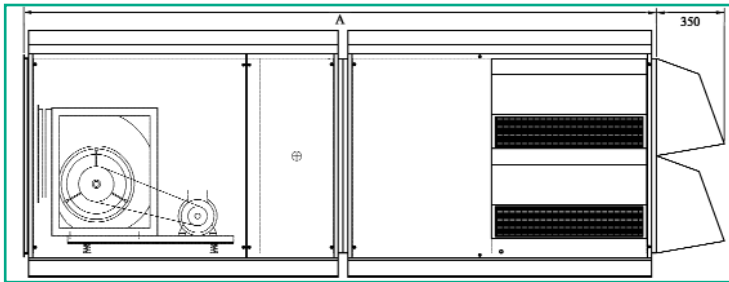
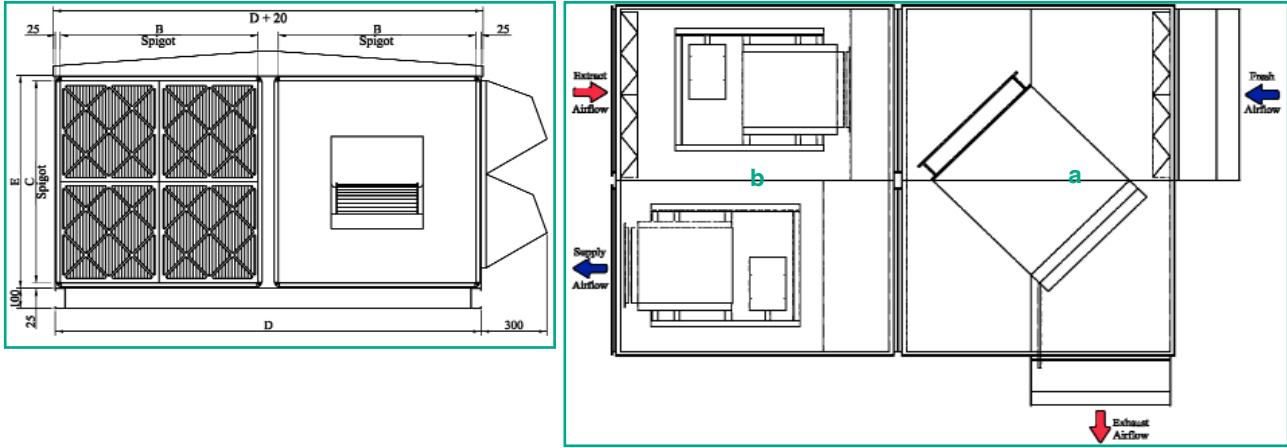

Model Roof	A mm	B mm	C mm	D mm	E mm	kg a	kg b
HRR7	3200	775	800	1700	850	380	500
HRR8	3300	975	1000	2100	1050	520	650

Stacked Configuration

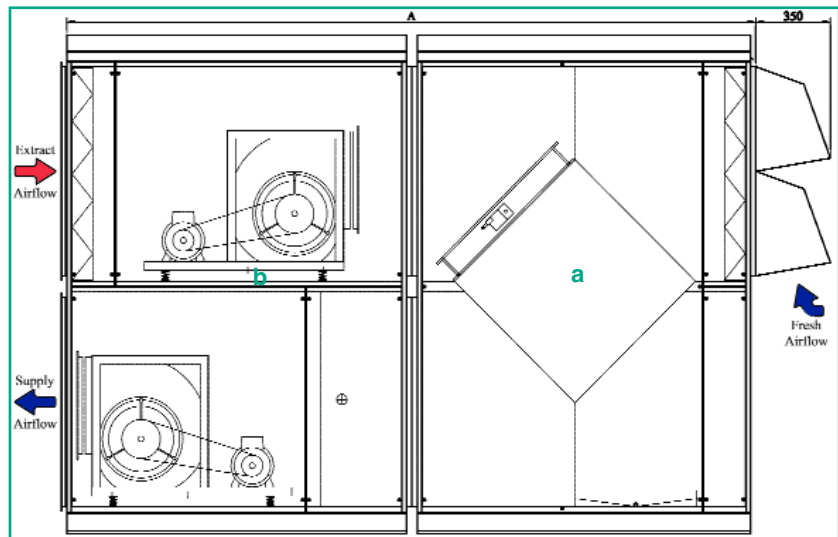
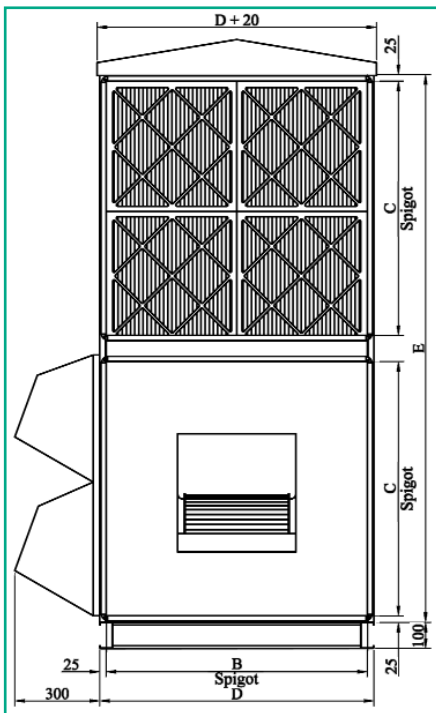

Model Roof	A mm	B mm	C mm	D mm	E mm	kg a	kg b
HRR7	3200	800	775	850	1700	380	520
HRR8	3300	1000	975	1050	2100	450	600

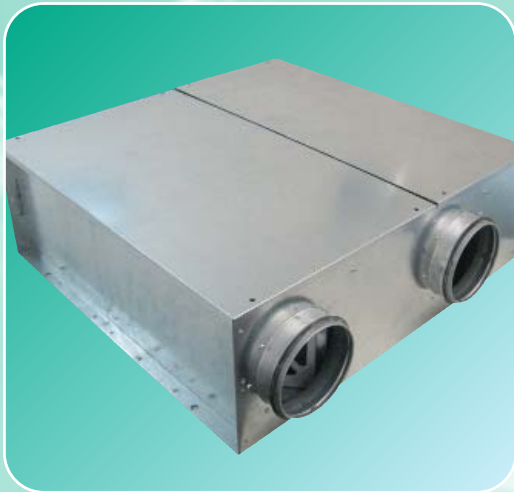

Certificate No: GB9455

Vectaire Ltd
Lincoln Road
Cressex Business Park
High Wycombe
Buckinghamshire, HP12 3RH
Tel: +44(0)1494 522333
Fax: +44(0)1494 522337
Email: sales@vectaire.co.uk
Web: www.vectaire.co.uk

